

# DESIGN NOTES

## Interfacing to Apple LocalTalk® Networks

Design Note 85

Robert Reay

### LocalTalk Overview

Of the many connection technologies available for linking an AppleTalk® network, LocalTalk is one of the most common because it is designed to connect local work groups using inexpensive and easily configurable plug-and-play cabling. LocalTalk is laid out in a bus topology with all devices joined in a line with no circular connections. LocalTalk conforms to the EIA RS422 electrical standard to provide a balanced differential voltage signal transmitting at 230.4kbs over a maximum distance of 300 meters with up to 32 devices connected to a twisted-pair network. The balanced configuration provides good isolation from ground noise currents and is not susceptible to fluctuating potentials between system grounds or common-mode electromagnetic interference (EMI).

### LTC1323

The original LocalTalk hardware design uses an AM26LS32 chip for the receivers and an AM26LS30 chip for the drivers of a LocalTalk port. The drawback of the design is that it requires two chips per port and an

external  $-5V$  supply. The bipolar chips also draw large supply currents, making them undesirable for battery-powered applications. A better solution is to use the LTC1323CS24 which provides a complete low power serial I/O interface while generating its own  $-5V$  supply as shown in Figure 1.

The LTC1323 uses the differential driver output stage of Figure 2. The driver swings between ground and  $V_{CC}$  when a differential LocalTalk load is connected between  $TXD^+$  and  $TXD^-$  while meeting the EIA RS422 differential voltage swing requirement of  $\pm 2.0V$  into  $100\Omega$ . When a single-ended load is connected from  $TXD^+$  to ground or  $TXD^-$  to ground, the driver will swing between  $V_{EE}$  and  $V_{CC}$  while meeting the EIA 562 voltage swing requirement of  $\pm 3.7V$  into  $3k\Omega$ . Because the differential LocalTalk load requires a large current drive, the charge pump that generates  $V_{EE}$  would be unreasonably large if the driver were to swing to  $V_{EE}$  with a differential load. By limiting the current flowing into  $V_{EE}$  to  $15mA$ , the charge pump can easily be integrated into the chip.

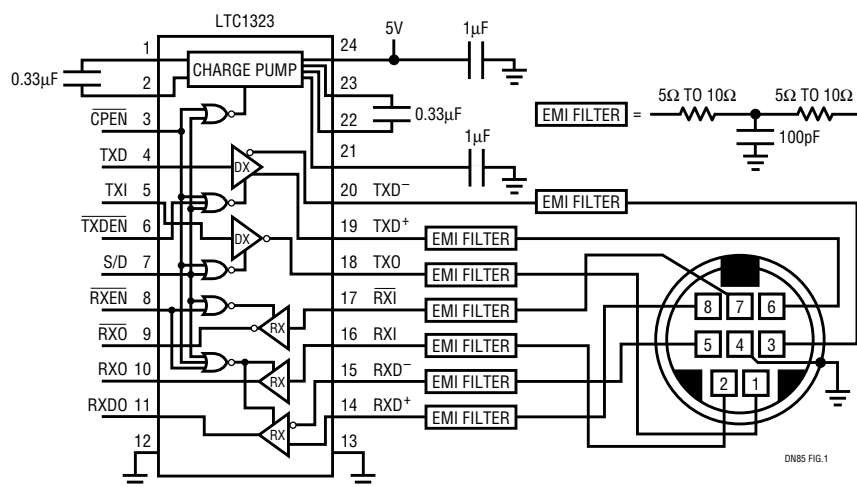

Figure 1. Single Supply LocalTalk Port

For applications where the single-ended control signals are not required, such as PhoneNet®, the LTC1323CS16 can be used as shown in Figure 3. The differential driver is still able to drive a single-ended load to  $V_{EE}$  when not connected to a LocalTalk network.

### LTC491

For PhoneNet-type applications where the differential driver is not required to drive a single-ended load below ground, the LTC491 can be used as shown in Figure 4. Only RS485 drivers will work in this application. RS422 drivers will not work because they load the cable when the chip power is removed.

### EMI Filter

Most LocalTalk applications use an electromagnetic interference (EMI) filter consisting of a resistor-capacitor T network between each driver and receiver and the connector (Figure 5). Unfortunately, the resistors significantly attenuate the driver's signal applied to the cable. Because the LTC1323 and LTC491 are single supply drivers, the resistor values should be reduced to  $5\Omega$  to  $10\Omega$  to insure enough voltage swing on the cable. In most applications, removing the resistors completely does not cause an increase in EMI as long as a shielded connector and cable are used. With the resistors removed, the only DC load becomes the primary of the LocalTalk transformer. This will increase the DC standby current when the drivers are active, but does not adversely affect the drivers because they can handle a direct short circuit indefinitely. For maximum swing and EMI immunity, a ferrite bead and capacitor could be used.

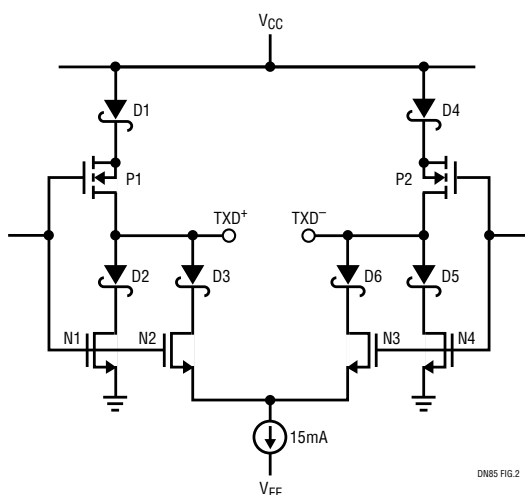

Figure 2. LTC1323 Differential Drive Output Stage

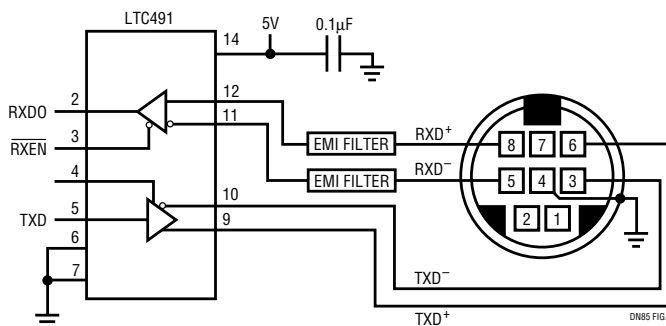

Figure 4. PhoneNet Application

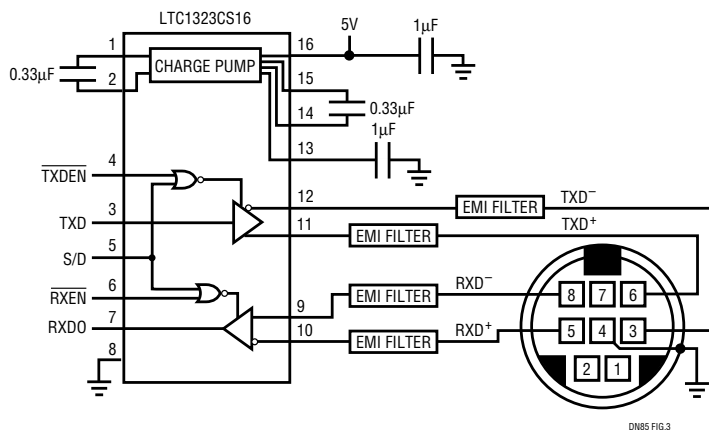

Figure 3. PhoneNet Application

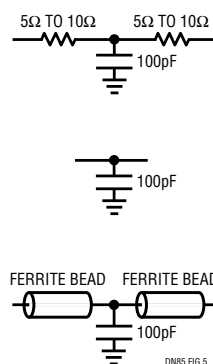

Figure 5. EMI Filters

For literature on our Interface Products, call **1-800-4-LINEAR**. For applications help, call (408) 432-1900, Ext. 453

PhoneNet is a registered trademark of Farallon, Inc.